

# Clarifying

## Vortex Attractor –MULTI-SURFACE ATTACHMENT DEVICE

- Vortex-based payload support
- Designed for tactical deployment
  - Holds position on most any surface
  - Simple to operate
  - Rugged
  - Battery powered
- Many applications:
  - Wall/ceiling/floor breaching
  - Communications/navigation aid
  - Unmanned sensing
- Run time of about 40 minutes
- Maximum payload is 3.5 lbs. (1.6 kg)
- Empty weight is 0.8 lbs. (0.36 kg)
- Underwater version available



Attractor Image

### Clarifying Vortex Attractor

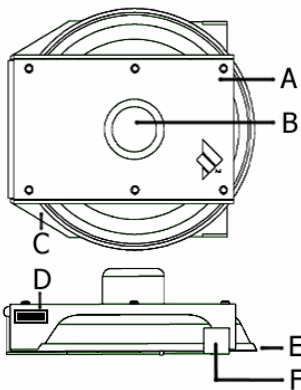

- A. Storage for batteries, peripherals, and wiring
- B. Motor housing and handle
- C. Fold out shelf, in stowed position
- D. Recessed power switch
- E. Rubber gasket/silencer
- F. Shelf tab to prevent movement of SLAM charge

